

# *Stress Measurement by Hydraulic Fracturing*

सिद्धवत् गाता यही रसा नः



**Rajbal Singh**

*Rock Mechanics Discipline  
Central Soil and Materials Research Station  
Olof Palme Marg, Hauz Khas,  
New Delhi 110016, India  
E-Mail: rajbal\_s@yahoo.co.in*

## **ABSTRACT**

The hydraulic fracturing tests were conducted to determine the in-situ state of stress to design the underground powerhouse in the present investigation. The average values of in-situ stresses in horizontal and vertical directions were interpreted based on orientations of the stresses obtained during the measurements. The hydraulic fracturing tests were conducted at two locations inside seven drill holes in the drifts excavated parallel and perpendicular to the axis of the underground powerhouse. The vertical stress was also calculated based on the height of the overburden at that location. The vertical stress due to overburden was found to be less than measured vertical stress. The evaluated in-situ stresses based on hydraulic fracturing tests were utilised for finalising the design and layout of the underground powerhouse.

**Keywords:** In-situ stresses; Hydraulic fracturing test; Underground powerhouse.

## **1. INTRODUCTION**

The in-situ stress field is one of the primary parameter influencing the analysis and performance of engineering structures located in a rock mass, be it a tunnel, a shaft or a cavern. Any attempt to design engineering structures in rock requires the knowledge of the prevailing in-situ stress field along with its direction. Over the years engineers and scientists, engaged in rock mechanics (ISRM 2003), have devoted considerable time and effort in the development of techniques for in-situ stress measurements and its application in the various fields of engineering.

Though the importance of in-situ stress measurement has long been felt in India, it is of late only that the measurement of in-situ stress has been taken up seriously. The natural stress pattern of Himalayas has not been well established so far and there is strong influence of topography and geology on in-situ stresses. In such a complex situation, any empirical approach for in-situ stress determination may lead to erroneous conclusion. Hence, it is always advisable to measure in-situ stresses, in whatever best way possible, and then to extrapolate or interpolate the result.

The Central Soil and Materials Research Station (CSMRS), New Delhi, conducted the hydraulic fracturing tests using Minifrac System at two locations in seven drill holes in the underground power house drift of Larji Hydroelectric Project in Himachal Pradesh for determining the in-situ stresses in the rock mass.

In this paper, the in-situ stresses determined inside the underground powerhouse at Larji Hydroelectric Project, Himachal Pradesh on the basis of hydraulic fracturing tests are presented along with interpretation of resulting in-situ stresses.

## **2. LARJI HYDRELECTRIC PROJECT**

The Larji Hydroelectric Project is located in Kullu District of Himachal Pradesh. It envisages the harnessing of hydropower potential of the river Beas in the Himalayas with a total capacity of 126 MW. Himachal Pradesh State Electricity Board (HPSEB) has constructed the project. The HPSEB has constructed a dam with a maximum height of 27 meters. The water to the underground powerhouse will be taken through intake on the right bank with underground desilting chambers and HRT of 8.5 m diameter and 4115 m length.

The layout plan of the project is shown in Fig 1. The plan showing the details of underground powerhouse area is shown in Fig. 2 along with the testing drift.

## **3. GENERAL GEOLOGY OF THE POWER HOUSE**

In the underground powerhouse area, rocks of Chail formation are exposed. Rock type is quartz chlorite mica schist. The strike of the rock varies between  $5^{\circ}$  W -  $5^{\circ}$  S E to N  $15^{\circ}$  W-S $15^{\circ}$  E with dips of  $30^{\circ}$  to  $50^{\circ}$  in South Westerly direction.

The hill slopes vary between  $25^{\circ}$  to  $30^{\circ}$  where overburden is present and up to  $50^{\circ}$  where rock is exposed. Rock is under thin cover of overburden along the road at EL 910 m. The rock to overburden contact occurs at higher elevations between 970-1000 m and the rock is moderately jointed and exhibit open relief joints towards left bank of Dwara nallah. The area below the road level up to the riverbank is covered with talus material, except at two places where exposures of bedrocks are seen.

## **4. HYDRAULIC FRACTURING TESTS**

### **4.1 In-situ Stress Measurements**

The importance of in-situ stress measurements for underground structures cannot be over emphasized and has been well established in the recent times by many researchers throughout the world (Amadei and Stephenson, 1992; Enever and Walton, 1987).

In recent years, it has been established that in-situ stress plays an important role in the location, design and construction of underground structures. Of many methods for in-situ stress measurements (ISRM 2003), hydraulic fracture technique has distinct advantages (Enever and Walton, 1987). Based on his experience Enever (1993) presented the case studies of in-situ stress measurements by hydraulic fracturing in Australia.

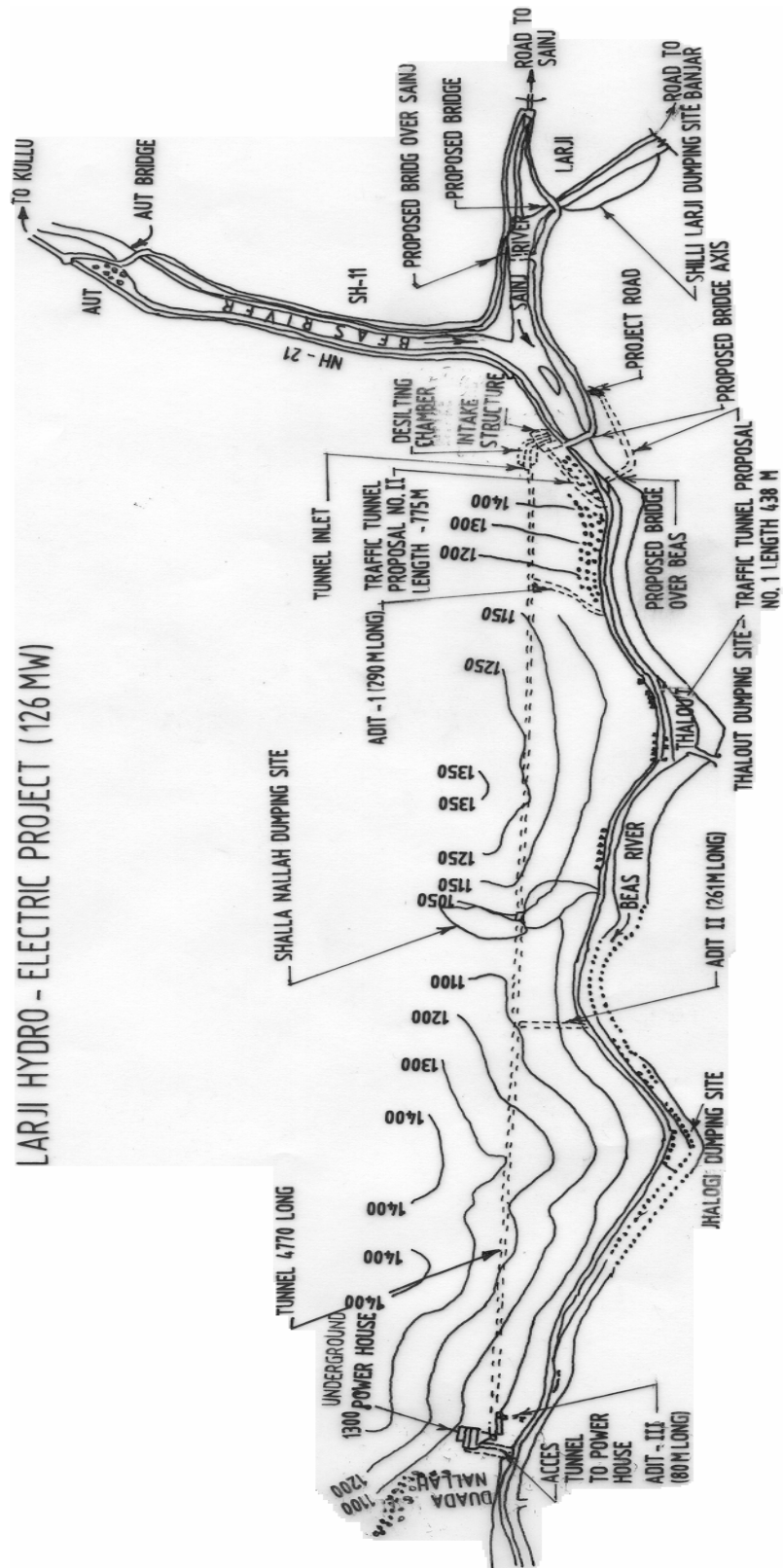

Fig. 1 - Layout plan of the Larji hydroelectric project

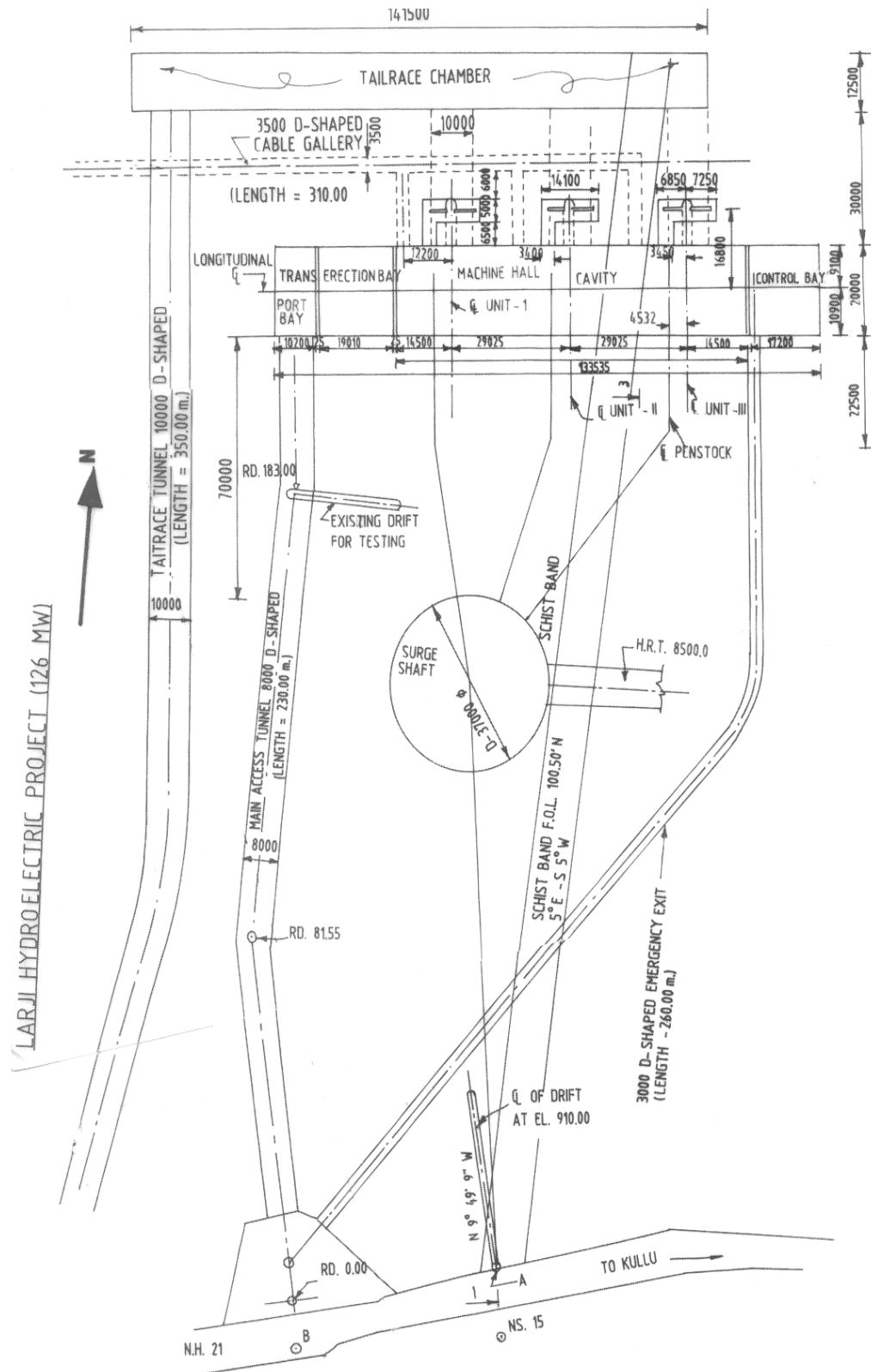

Fig. 2 - Plan of underground powerhouse and the testing drift

In this project, hydraulic fracturing tests were conducted as the designers have realised that the measurement of the magnitude and the direction of the in-situ stresses would be an additional engineering parameters for the design of powerhouse.

## 4.2 Hydraulic Fracturing Test

Hydraulic fracturing involves applying hydraulic pressure to a drill hole to determine the fracture pressure and hence the stress. The method essentially consists of:

- selecting test locations after inspecting the rock cores of the drill hole,
- isolating the test section with the help of packers,
- pressurizing the test location to obtain a fracture in the rock,
- obtaining a pressure time record,
- obtaining the impression of the crack on an impression packer, and
- evaluation of magnitude and direction of in-situ stresses.

The basic elements of hydraulic fracturing tests are shown in Fig. 3.

## 4.3 Minifrac System

The Minifrac equipment makes use of pumps for packer inflation and pressurisation of the test interval respectively. The packer pressure and test pressure are sensed throughout the test by transducers and are recorded on chart recorder.

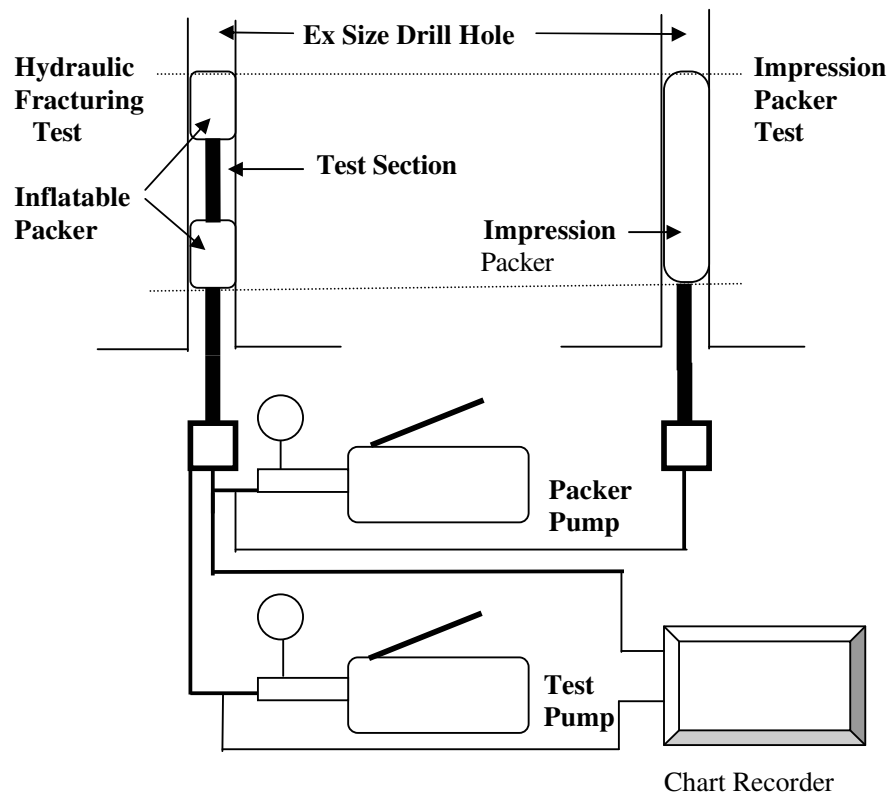

Fig. 3 - Schematic diagram of hydraulic fracturing equipment

The CSIRO Minifrac system has been shown in Fig. 4 (CSIRO, 1991). This Minifrac hydraulic fracturing equipment is used for determination of in-situ stresses in Ex sized drill hole (38 mm diameter) up to a depth of about 30m with an operational pressure of 35 MPa.



Fig. 4 - Photograph of hydraulic fracturing equipment

The brief details of equipment are described in the following paragraphs. The equipment consists of the following main components:

- Installation and test tools comprising of installation rods, hydraulic fracturing tools, Impression tools etc.
- Pressurisation and recording system comprising of hydraulic tank, hand pumps, instrument panel with pressure gauge, chart recorder, test and packer hoses etc. (Fig. 3).

**Installation rods:** They are precision machined and fabricated from stainless steel and can deliver hydraulic fluid pressure in excess of 35 MPa and are strong and torsionally rigid.

**Minifrac tools:** The system is supplied with two sets of the fracturing tools and impression packers. The tools are manufactured to a nominal diameter of 36mm for use in diamond drilled Ex (38mm) sized drill hole. The tools are tested to a maximum operational pressure of 35 MPa.

**Hydraulic circuit:** The hydraulic circuit comprises the dual pressurisation system (hand pumps and tanks) distributed through manifolds to the measurement and control

instrument and also through long flexible hoses and installation rods to the tools.

**Hydraulic fluid:** Comprising 10-20:1 ratio of clean water with water-soluble oil (cutting oil); used as pressurising fluid.

#### 4.4 Test Procedure

The field test procedure involves an initial fracturing followed by a number of cycles of pressures. Initial fracturing is accomplished by increasing the pressure in the test section along with increase in the packers. Pumping is stopped as soon as a crack is formed (sudden drop in test section pressure) in order to preserve the initial geometry (as recorded by the impression packer) and to allow a first shut in pressure to be recorded on the chart recorder. Water, with soluble oil, has been used and found to be the most appropriate and convenient test fluid.

A relatively slow pressure rate is employed to ensure that the initiated crack retains its initial geometry during the first shut in phase.

The test pressure is vented to atmosphere between cycles of pressures to allow the induced crack to close. A build up of pressure in the test interval upon temporarily sealing the system during venting is taken as evidence of continued flow of fluid out of a closing crack. Venting is continued until this phenomenon ceases.

Further cycles of pressures and venting are used to determine the crack re-opening pressure and to gauge whether the orientation of the crack changes as it is propagated. Thus records of pressure versus time are obtained during the tests. The pressure time record from hydraulic fracturing test with main features of test cycles is shown in Fig. 5.

The impression of the crack is taken on the impression packer by lowering it in the drill hole at the test location and applying pressure taking into account the orientation of the lowering rods as well as the fracture initiation/reopening pressure. The direction of the crack is marked on the impression packer and recorded on the record sheet. This direction of crack gives the direction of maximum and minimum stresses in a plane perpendicular to the drill hole axis.

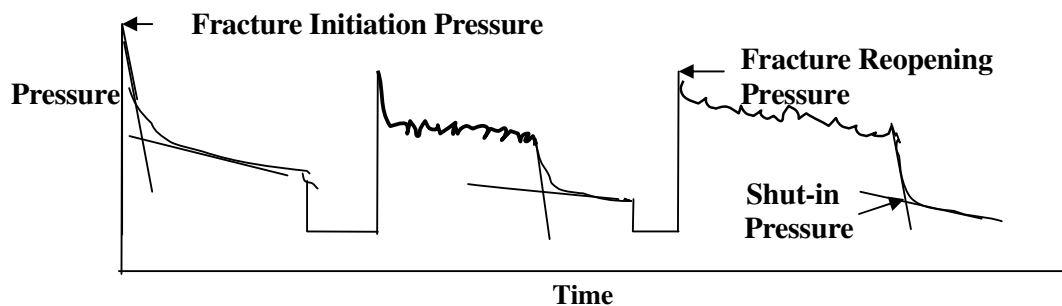

Fig. 5 - Pressure time record of hydraulic fracturing test

#### 4.5 Interpretations of Stresses

The fundamental principle underlying the application of hydraulic fracturing is that

- one of the principal stress components is co-axial with the test hole,
- the long-term shut in pressure is approximated as the magnitude of the smaller horizontal stress component, and
- the crack will generally tend to initiate in a plane normal to minimum stress (i.e. parallel to maximum stress).

In the case of an approximately axial fracture in a hole, the test pressure record can be used to estimate the magnitude of secondary principal stresses in the plane normal to the drill hole axis.

The magnitude of maximum secondary principal stress component for impermeable rocks is determined from the expression:

$$\sigma_{1'} = 3 \sigma_{2'} + S - P_i - P_o \quad (1)$$

where,

- $\sigma_{1'}$  = maximum secondary stress,
- $\sigma_{2'}$  = minimum secondary stress,
- S = fracture strength of the rock,
- $P_i$  = fracture initiation pressure, and
- $P_o$  = ambient pore pressure.

The magnitude of minimum secondary principal stress is equal to the shut-in pressure ( $S_i$ ). Therefore,

$$\sigma_{2'} = S_i \quad (2)$$

The fracture strength, S can be found from the expression:

$$S = P_i - P_r \quad (3)$$

where  $P_r$  is the fracture reopening pressure.

Equation 3 can also be rewritten as

$$S - P_i = - P_r \quad (4)$$

Neglecting  $P_o$  term, as the ambient pore pressure can normally be assumed to have been dissipated in the close proximity of an underground opening, the Eq. 1 can be rewritten as follows with the help of Eq. 4:

$$\sigma_{1'} = 3 \sigma_{2'} - P_r \quad (5)$$



$P_i$ ,  $P_r$  and  $S_i$  can be obtained from pressure time record.  $S_i$  is calculated by the double tangent method as shown in Fig. 5.

The vertical stress can be estimated from the overburden by

$$\sigma_v = \gamma h \tag{6}$$

where,

- $\sigma_v$  = vertical stress,
- $h$  = depth of overburden, and
- $\gamma$  = average unit weight of rock mass.

Directions of the stresses are determined from the impressions of the cracks obtained on the impression packer. These directions are obtained with reference to the direction of the drill hole.

### 5. TEST LOCATIONS

The hydraulic fracturing tests using minifrac system were conducted at two locations in the powerhouse area. Four Ex size drill holes - one on the right wall, one on the left wall, one on the face and one at the crown were drilled in cross drift and main drift, respectively. The locations of the tests are schematically shown in Fig. 6. Rock type in the powerhouse area is quartz chlorite mica schist. As shown in Fig. 2, the locations of the tests are not exactly in the underground powerhouse.

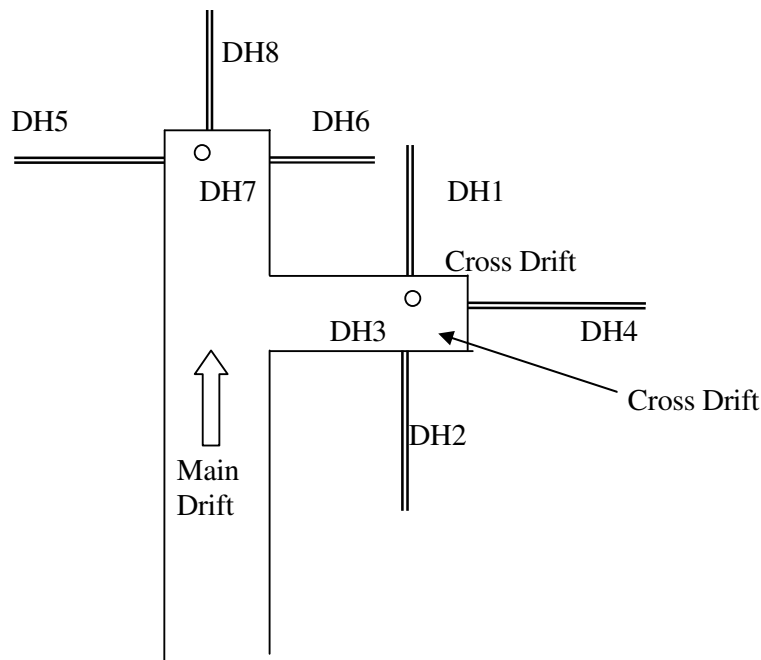

Fig. 6 - Locations of the drill holes in powerhouse at RD 188m + 34 m (cross drift) and at RD 197 m (main drift)

## 6. RESULTS AND DISCUSSIONS

### 6.1 Hydraulic Fracturing Tests Inside Cross Drift at RD-188m + 34m

In all 15 hydraulic fracturing tests (HFT) and 15 impression packer tests (IPT) were conducted at this location inside 4 drill holes (Fig. 6). The tests were conducted at all the locations wherever sufficient core length of more than 25 cm was available. The pressure versus time curves for one typical hydraulic fracturing test is shown in Fig. 5. The in-situ stresses predicted on the basis of hydraulic fracturing tests are presented in Table 1.

Table 1 - In-situ stresses by hydraulic fracturing tests at RD 188m + 34m (cross drift)

Test No.	Test Depth m	$P_i$ MPa	$P_r$ MPa	$S_i$ MPa	$\sigma_2$ MPa	$\sigma_1$ MPa	Orientation of stress with respect to the top of the Drill hole Degree
HFT1	12.50	16.10	7.70	5.50	5.50	8.80	Axial 112
HFT 2	11.80	15.10	8.75	6.00	6.00	9.25	Axial 90
HFT 3	11.00	13.50	5.60	2.15	2.15	0.85	Axial under packer 108
HFT 4	16.00	17.15	16.30	14.35	14.35	25.75	Axial under packer -
HFT 5	16.30	15.95	13.65	12.50	12.50	24.25	Axial under packer 10
HFT 6	11.20	17.50	16.50	12.40	12.40	20.75	Large transverse 150 and under packer
HFT 7	10.80	13.65	15.05	10.30	10.30	15.85	Transverse and 143 Under packer
HFT 8	10.30	16.45	14.00	11.20	11.20	19.60	Axial towards packer 20
HFT 9	20.70	17.50	11.30	10.50	10.50	20.20	Axial under packer 10
HFT 10	20.18	13.65	9.45	5.60	5.60	7.35	Axial 160
HFT 11	17.70	17.30	15.40	14.80	14.80	29.00	Transverse and 170 under packer
HFT 12	7.42	8.00	6.40	3.50	3.50	4.50	Transverse rotating -
HFT 13	18.32	10.60	7.00	3.50	3.50	3.50	Transverse rotating 90
HFT 14	2.75	13.65	6.70	3.80	3.80	5.70	Rotating inclined 80
HFT 15	2.00	12.40	4.90	3.50	3.50	5.60	Transverse rotating 90

It is seen from the Table 1 that a very high magnitude of stresses was measured in all the cases where fractures were under the packer as is evident from impression packer tests. It is difficult to predict the in-situ stresses wherever fractures were initiated under the packer. In HFT 3 the magnitude of stresses was very low and maximum secondary stress was less

than the minimum secondary stress. It was, therefore, decided not to include these results for the final analysis.

It was possible to include data of only 7 hydraulic fracturing tests out of 15 for the final analysis at this location. In the analysis of in-situ stresses based on hydraulic fracturing test and impression packer test minimum horizontal stress, maximum horizontal stress, and vertical stress were predicted. The in-situ stresses based on this analysis are presented in Table 2.

The average minimum and maximum horizontal stresses and average vertical stresses based on hydraulic fracturing tests are 4.98 MPa, 8.47 MPa and 4.30 MPa, respectively.

Overburden was about 200 meters at this location. The vertical stress based on overburden was 5.40 MPa, which was higher than the measured vertical stress of 4.30 MPa.

Table 2 - Average in-situ stresses at RD-188m +34m (cross drift)

Test No.	Orientation of Drill Hole	Measured Stresses			Orientation of Fracture with respect to Top of the drill hole Degrees
		$\sigma_h$ MPa	$\sigma_H$ MPa	$\sigma_v$ MPa	
HFT 1	Horizontal left	--	8.80	5.50	Axial 112
HFT 2	Horizontal left	--	9.25	6.00	Axial 90
HFT 10	Vertical hole	5.60	7.35	--	Axial 160*
HFT 12	Vertical hole	4.50	--	3.50	Transverse*--
HFT 13	Horizontal face	3.50	--	3.50	Transverse 90
HFT 14	Horizontal face	5.70	--	3.80	Rotating 80
HFT 15	Horizontal face	5.60	--	3.50	Transverse Rotating 90
Average stresses		4.98	8.47	4.30	

\* Orientation with respect to North in Vertical drill holes.

## 6.2 Hydraulic Fracturing Test Inside Main Drift at RD – 197 m

Four holes were drilled at this location. In all 9 tests were conducted inside 3 drill holes. However, the drill hole at the face could not be utilised for conducting hydraulic fracturing test due to the damage of hydraulic fracturing tool while conducting test inside the vertical drill hole in the crown.

In-situ stresses predicted based on these tests are presented in Table 3. It is seen from Table 3 that fractures were initiated under packer in the case of test HFT 2 and HFT 7. In the case of test HFT 1, maximum secondary stress, predicted was less than that of minimum secondary stress. It was, therefore, decided not to include the data from these 3

tests for the final analysis. The results of 6 tests were analysed and presented in Table 4.

The average values of minimum horizontal stress, maximum horizontal stress and vertical stress based on hydraulic fracturing and impression packer tests are 4.40 MPa, 6.71 MPa and 4.30 MPa, respectively.

Table 3 - In-situ stresses by hydraulic fracturing tests at RD 197m (main drift)

Test No.	Test Depth m	$P_i$ MPa	$P_r$ MPa	$S_i$ MPa	$\sigma_2$ MPa	$\sigma_1$ MPa	Orientation of Stress with respect to Top of Drill Hole, Degrees
HFT 16	12.15	8.40	5.25	1.40	1.40	1.05	Axial 100
HFT 17	13.85	11.20	5.60	1.40	1.40	1.75	Axial 60
HFT 18	14.80	7.70	3.60	2.80	2.80	4.20	Transverse -
HFT 19	4.75	10.15	6.65	4.20	4.20	6.60	Inclined 140
HFT 20	12.20	15.75	8.75	7.00	7.00	12.25	Inclined 130
HFT 21	13.60	9.80	7.35	4.55	4.55	6.65	Transverse -
HFT 22	18.70	14.70	10.15	7.00	7.00	14.00	Inclined -
HFT 23	10.80	11.90	8.40	2.10	2.10	2.80	Axial 94
HFT 24	14.35	9.45	8.40	5.60	5.60	9.10	Axial 99

Table 4 - Average in-situ stresses at RD-197m (cross drift)

Test No.	Orientation of Drill Hole	Measured Stresses			Orientation of Stress with respect to top of the Drill Hole, Degrees
		$\sigma_h$ MPa	$\sigma_H$ MPa	$\sigma_v$ MPa	
HFT 18	Horizontal left	2.80	4.20		Transverse --
HFT 19	Horizontal right	--	6.60	4.30	Inclined 140
HFT 20	Horizontal right	7.00	12.50	--	Inclined 130
HFT 21	Horizontal right	4.50	6.65	--	Transverse --
HFT 23	Vertical hole	2.10	2.80	--	Axial 94*
HFT 24	Vertical hole	5.60	7.53	--	Axial 99*
Average stresses		4.40	6.70	4.30	

\* Orientation with respect to North in vertical drill holes.

### 6.3 In-Situ Stresses in the Vicinity of Powerhouse

The hydraulic fracturing tests using Minifrac system were conducted at two locations in the vicinity of the underground power house inside quartz chlorite mica schist rock mass. The in-situ stresses predicted at both the locations in the vicinity of the underground power house are shown in Table 5.

The average values of minimum horizontal stresses, maximum horizontal stresses and vertical stresses on the basis of 13 hydraulic fracturing tests and an equal number of impression packer tests are 4.70 MPa, 7.30 MPa and 4.30 MPa, respectively. The stress ratio of maximum horizontal stress to vertical stress was 1.7. However, the stress ratio of minimum horizontal stress to vertical stress was 1.1.

Overburden was about 200 meters at test location. The vertical stress based on overburden was 5.40 MPa, which was higher than measured vertical stress of 4.30 MPa.

Table 5 - In-situ stresses in the vicinity of underground powerhouse

Test No.	Orientation of Drill Hole	Measured Stresses			Orientation of Stress with respect to Top of the Drill Hole Degrees
		$\sigma_h$ MPa	$\sigma_h$ MPa	$\sigma_v$ MPa	
HFT 1	Horizontal left	--	8.80	5.50	Axial 112
HFT 2	Horizontal left	--	9.25	6.00	Axial 90
HFT 10	Vertical hole	5.60	7.35	--	Axial 160*
HFT 12	Vertical hole	4.50	--	3.50	Transverse*--
HFT 13	Horizontal face	3.5	--	3.50	Transverse 90
HFT 14	Horizontal face	5.70	--	3.80	Rotating 80
HFT 15	Horizontal face	5.60	--	3.50	Transverse Rotating 90
HFT 18	Horizontal left	2.80	4.20	--	Transverse --
HFT 19	Horizontal right	--	6.60	4.30	Inclined 140
HFT 20	Horizontal right	7.00	12.50	--	Inclined 130
HFT 21	Horizontal right	4.50	6.65	--	Transverse
HFT 23	Vertical hole	2.10	2.80	--	Axial 94*
HFT 24	Vertical hole	5.60	7.53	--	Axial 99*
Average stresses		4.70	7.30	4.30	

\* Orientation with respect to North in Vertical drill holes.

## 7.0 CONCLUSIONS

The following conclusions have been drawn based the present stress measurements:

- For the prediction of in-situ stresses inside the underground powerhouse, 24 hydraulic fracturing and 24 impression packer tests were conducted at two locations inside 7 drill holes. The data of 13 hydraulic fracturing and 13 impression packer tests was included in the analysis of in-situ stresses.
- The following average values of in-situ stresses were recommended to be adopted for the design of underground power house:
  - Minimum horizontal stress,  $\sigma_h$  = 4.70 MPa
  - Maximum horizontal stress,  $\sigma_H$  = 7.30 MPa
  - Vertical stress,  $\sigma_v$  = 4.30 MPa
- The horizontal stresses were higher than the vertical stress. The stress ratio of maximum horizontal stress to vertical stress was 1.7. However, the stress ratio of minimum horizontal stress to vertical stress was 1.1.
- In general, the orientation of maximum horizontal stress was towards East-West. So the tentative orientation of the underground powerhouse was also fixed in the East-West direction.
- The vertical stress due to overburden was 5.40 MPa, which was more than the vertical stress of 4.30 MPa as determined in the present investigation by conducting hydraulic fracturing test. It was, therefore, concluded that the in-situ stresses must be measured by any available method and it must not be evaluated based on overburden.

## References

- Amadei, B and Stephenson, (1992). In-situ stress measurements in rock for water resources projects, Vol. III of training course at CSMRS, New Delhi.
- CSIRO (1991). CSIRO Minifrac system operational manual, Mindata Pvt. Ltd., Australia, March.
- Enever, J.R. (1993). Case Studies of Hydraulic Fracturing Stress Measurement in Australia, Comprehensive Rock Engg., Edited by Prof. J.A. Hudson, Vol. 3, pp. 497-532.
- Enever, J.R. and Walton, R.J. (1987). Rock stress measurement techniques, CSIRO Division of Geomechanics, Melbourne, Australia.
- ISRM (2003). ISRM suggested methods for rock stress estimation, International Journal for Rock Mechanics and Mining Sciences, 40, pp. 991-1025.